



## Chopper 5000 H S5

### Manual tool change

Item no. **11205010**

HF-Spindle for high-speed milling, -grinding, -drilling, -engraving

### Bearings

Steel ball bearing (pcs)	3
Lifetime lubricated	maintenance free

### Motor

Motor technology	3-phase asynchronous drive (no brushes or sensors)
Frequency	500 Hz
Motor poles (pairs)	1
Rated rotation speed	30.000 rpm
Acceleration/braking value Per second	10 000 rpm (other values by consultation)

### Power values

#### Liquid cooled

	Pmax./5s	S6-60%	S1-100%	
Rated power	7,5	6,5	5	[kW]
Torque	2,9	2,4	1,7	[Nm]
Voltage	380	380	380	[V]
Current	19	14,5	10,3	[A]

## Chopper 5000 H S5

Manual tool change  
Item no. **11205010**

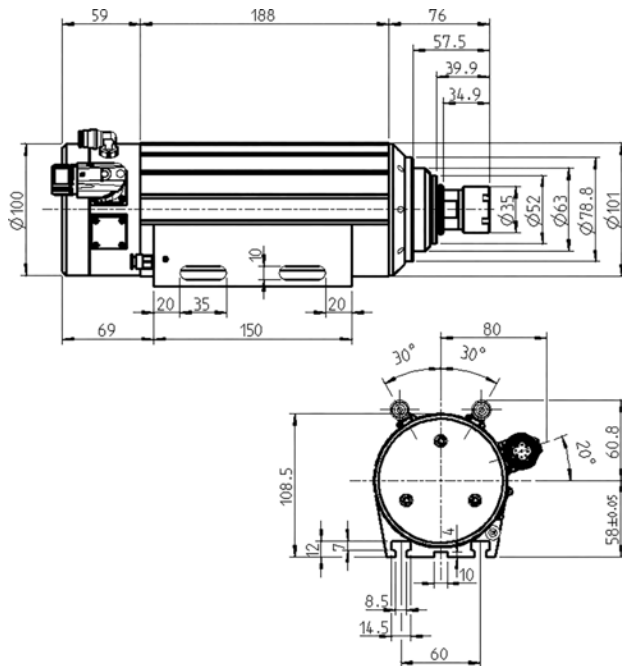

Dimensions

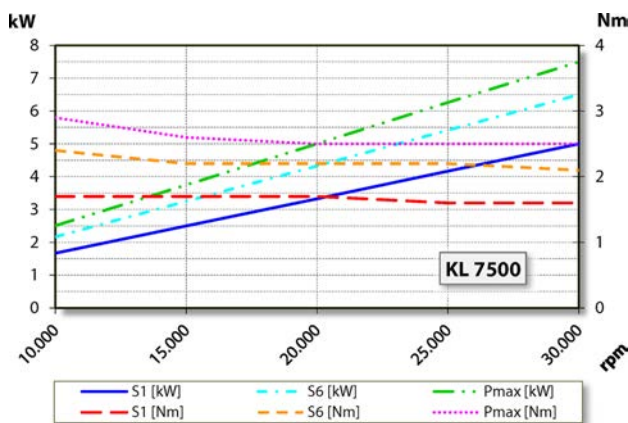

Performance Diagram

Liquid cooled

Measurement of power is funded by in-house testing.

## Characteristics

Speed sensor	Differential magneto resistor (TTL) Number of signals = 6
Motor protection	PTC 130°C Optional accessory
Housing	Aluminium
Housing diameter	100 mm
T-slots	DIN 650-8
Spindle holder integrated	
Cooling	Liquid cooled
Ambient temperature	+ 10°C ... + 45°C
Sealing air	
Protection category (sealing air turned on)	IP54
Tool change	Manual tool change
Collet type	ER 25 Optional accessories
Clamping range up to	16 mm (5/8" )
Clockwise	
Coupler plug	9-pin (SpeedTEC)
Weight	~ 9,4 kg
Inner taper run out	< 2 μ