

B88-M220.01 K1.15S3A

Manual tool change

Item no. **10002001**

HF-Spindle for high-speed sawing

Bearings

Steel ball bearing (pcs)	2
Lifetime lubricated	maintenance free

Motor

Motor technology	3-phase asynchronous drive (no brushes or sensors)
Frequency	667 Hz
Motor poles (pairs)	2
Rated rotation speed	20.000 rpm
Acceleration/braking value Per second	10 000 rpm (other values by consultation)

Power values

Uncooled

	Pmax./5s	S6-60%	S1-100%	
Rated power	2	1,6	1,4	[kW]
Torque	1,4	0,96	0,84	[Nm]
Voltage	179	178	180	[V]
Current	8,6	6,5	6	[A]

B88-M220.01 K1.15S3A

Manual tool change
Item no. **10002001**

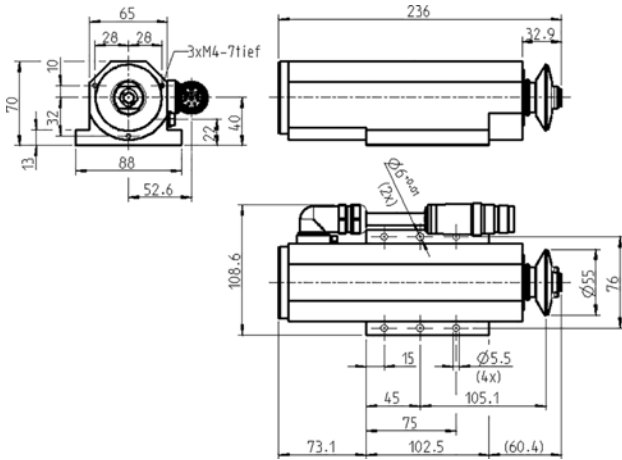

Dimensions

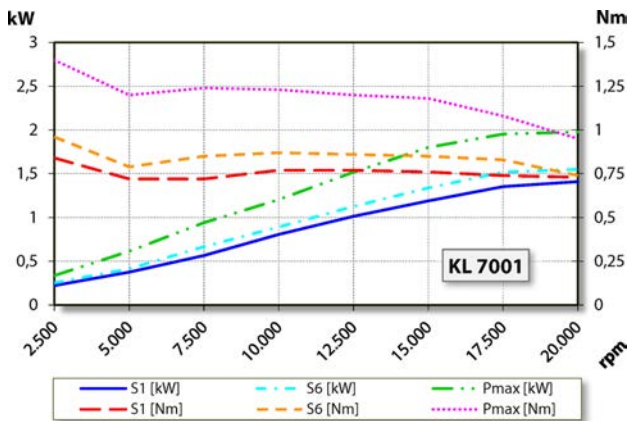

Performance Diagram
Uncooled

Measurement of power is funded by in-house testing.

Characteristics

Speed sensor	Differential magneto resistor (TTL) Number of signals = 6
Motor protection	PTC 160°C
Housing	Aluminium
Flange area	102,5 mm x 88 mm
Cooling	Compressed air cooled
Heat dissipation	Via the housing
Housing temperature	< + 45° C
Ambient temperature	+ 10°C ... + 45°C
Sealing air	
Protection category (sealing air turned on)	IP54
ESD protection	
Tool change	Manual tool change
Tool mount	Disc tool dia. 16 mm maximum t = 3 mm
Anticlockwise	
Coupler plug	8-pin (SpeedTEC) Cable length 1,15 m
Weight	~ 2,1 kg
Axial run-out of mounting surface	< 1 μ